

RH2512M

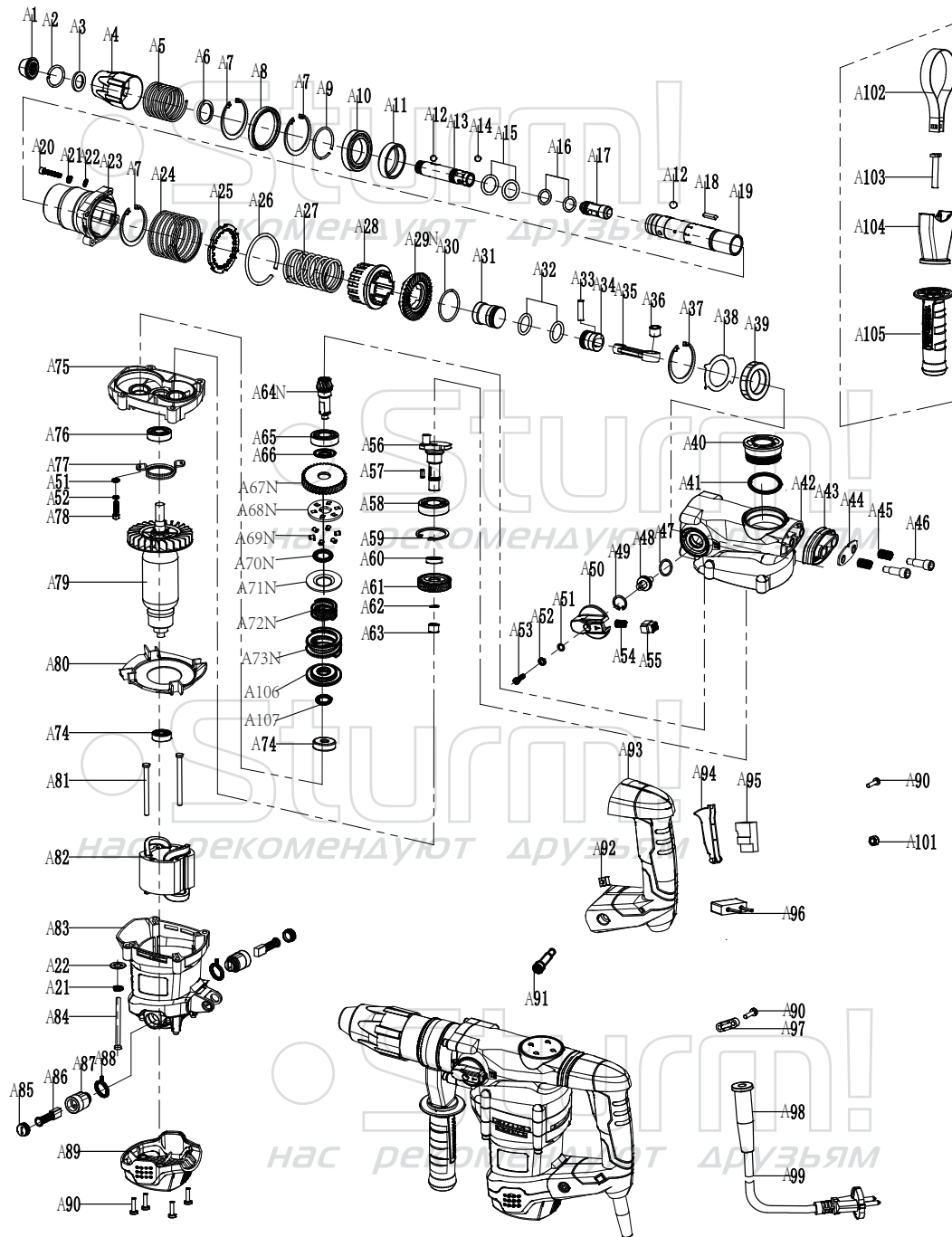

NO.	DESCRIPTION	NO.	DESCRIPTION
A1	RUBBER HEAD	A54	SPRING 0.6*4.5*17.5
A2	STEEL RING 23.5X2	A55	LOCKING BUTTON
A3	WASHER 38.5*26.2*4	A56	CRANK
A4	SLIDER	A57	FLAT PIN 4*4*12
A5	SLIDER SPRING 32*1.8*60	A58	BEARING 6204
A6	WASHER 30.5*40.5*1.5	A59	CRICLIP 47
A7	CRICLIP 55	A60	DISTANCE RING 17.1*26*7
A8	SEAL RING 35*55*8	A61	THE FIRST GEAR
A9	STEEL RING 31.5*1.6	A62	CIRCLIP 17
A10	BEARING 6907	A63	NEEDLE BEARING HK14/16
A11	PLASTIC RING	A64N	CONE SHAFT
A12	STEEL BALL Ø7.94	A65	BEARING 6002
A13	TELEFLEX	A66	WASHER 14.1*19*0.5
A14	STEEL BALL Ø7.14	A67N	BIG GEAR
A15	O-RING 24*2.2	A68N	CLUTCH BOARD
A16	O-RING 15*2	A69N	STEEL PIN 4X6
A17	IMPACT HAMMER	A70N	CIRCLIP 12.5X1
A18	FLAT KEY 3*3*18	A71N	DOWN CLUTCH BOARD
A19	CYLINDER	A72N	CLUTCH SMALL SPRING
A20	SCREW M6*30	A73N	CLUTCH BIG SPRING
A21	SPRING WASHER 6	A74	BEARING 628
A22	PLAIN WASHER 6	A75	MIDDLE COVER
A23	CYLINDER HOUSE	A76	BEARING 6001
A24	SPRING 50.8*1.6*50	A77	BEARING PRESS BOARD
A25	WASHER	A78	SCREW M4X14
A26	STEEL RING 60X2	A79	ROTOR
A27	SPRING	A80	WIND GUIDE
A28	CLUTCH	A81	SCREWST4.8X60
A29N	BIG CONE GEAR	A82	STATOR
A30	O-RING 28X1.8	A83	HOUSING
A31	RAMMER	A84	SCREWM6*60
A32	O-RING 22X3	A85	BRUSH COVER
A33	PISTON PIN 8*27	A86	CARBON BRUSH
A34	PISTON 28*26	A87	BRUSH HOLDER
A35	CONNECT ROD	A88	COIL SPRING
A36	NEEDLE BEARING HK1210	A89	REAR COVER
A37	CIRCLIP 50	A90	TAPPING SCREW ST3.9C16
A38	ANTI-OIL BOARD	A91	SCREWM8X45
A39	BUSH	A92	POWER INDICATOR LIGHT
A40	OIL COVER	A93	HANDLE
A41	O-RING 31.5*2	A94	SWITCH TRIGGER
A42	GEAR BOX	A95	POWER SWITCH
A43	ANTI-VIBRATION HOLDER	A96	CAPACITOR
A44	ANTI-VIBRATION BOARD	A97	CABLE CLAMP
A45	ANTI-VIBRATION SPRING	A98	CABLE SLEEVE
A46	ANTI-VIBRATION SCREW	A99	CABLE
A47	O-RING 175*2	A101	NUT M8
A48	DIAL TWIST	A102	HOOP
A49	CIRCLIP 21	A103	T-BOLT M8X50
A50	TWO FUNCTION KNOB	A104	BRACKET
A51	SPRING WASHER 4	A105	AUXILIARY HANDLE
A52	PLAIN WASHER 4	A106	SPRING SEAT
A53	SCREW M4*12	A107	CIRCLIP 8.5X1.2